



2-2.5 t

**G2 SERIES AC ELECTRIC
REACH TRUCK (STAND-ON TYPE)**

HELIFORKLIFT.CA

Manufacturer's Data and Design Characteristics

Character						
1.01	Manufacturer			HELI		
1.02	Model			CQD20		CQD25
1.03	Configuration number			GC2R		GC2R
1.04	Load capacity	Q	kg	2000		2500
1.05	Load center distance	C	mm	500		
1.06	Power mode			Battery		
1.07	Driving mode			Stand-on		
1.08	Wheel base	Y	mm	1515		1685
Tire						
2.01	Tire type			Polyurethane		
2.02	Wheel number, drive/caster/load (X=drive wheel)			1x/2/2		
2.03	Track Width,load	b3	mm	1078		
2.04	Wheel size, load		mm	ø285x100		
2.05	Wheel size, drive		mm	ø330x114		
2.06	Wheel size, caster		mm	ø178x76		
Size						
3.01	Lift height	h3	mm	3300		3300
3.02	Free lift	h2	mm	80		80
3.03	Mast height, lowered	h1	mm	2424		2424
3.04	Fork size, thickness/width/length	s/e/l	mm	40x122x920		40x122x1070
3.05	Fork adjusting width		mm	244~722		244~722
3.06	Fork sideshifting		mm	±55		±55
3.07	Truck body length(fork excluded)	L	mm	1906		2076
3.08	Truck body width	b1	mm	1190		1190
3.09	Distance between support arms	b2	mm	846		846
3.10	Reach distance	l4	mm	675		845
3.11	Height of overhead guard	h4	mm	2250		2250
3.12	Ground clearance,below mast	m2	mm	83		83
3.13	Turning radius	Wa	mm	1795		1965
3.14	Distance from fork front tip to center of load wheel	X	mm	467		637
3.15	Aisle width with pallet 1100L x 1100W, clearance 200	Ast	mm	2835		2885
3.16	Aisle width with pallet 1000L x 1100W, clearance 200	Ast	mm	2760		2825
Performance						
4.01	Travelling speed,with/without load		km/h	10/11.5		10/11.5
4.02	Lifting speed,with/without load		m/s	0.3/0.45		0.27/0.45
4.03	Lowering speed,with/without load		m/s	0.5/0.45		0.5/0.45
4.04	Reach speed,with/without load		m/s	0.1/0.1		0.1/0.1
4.05	Maximum climbing ability,with/without load		%	10/15		10/15
Weight						
5.01	Total weight(with battery)		kg	3200		3250
Battery						
6.01	Battery voltage/capacity k5		V/Ah	48/420		48/450
6.02	Battery weight		kg	750		780
6.03	Battery box dimension		mm	1035x352x784		11035x352x784
Motor and controller						
7.01	Drive motor power		kw	5		5
7.02	Lifting motor power		kw	10		10
7.03	Steering motor power		kw	0.6		0.6
7.04	Type of driving control			MOSTET/AC		
7.05	Type of lifting control			MOSTET/AC		
7.06	Type of steering control			MOSTET/AC		
7.07	Transmission box			HELI special transmission box		
7.08	Service brake			Electrical		

NOTE: Detailed information about battery,please contact our salesmen or engineer.

AST: Right angle stacking aisle width
Clearance a=200

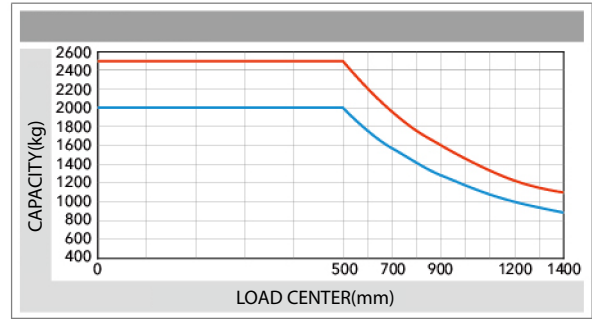
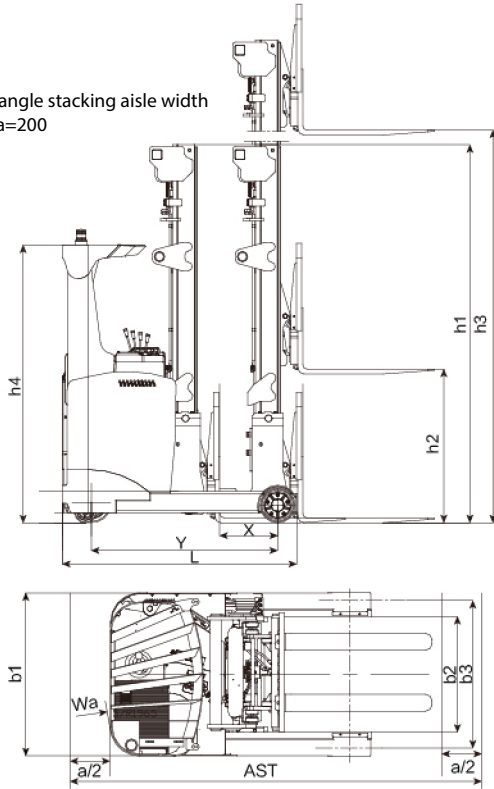

Note: The vertical axis stand for load capacity and the horizontal axis stand for load center which is calculated from the front surface of the forks to the gravity of the standard load. The standard load mean a cubic with 1000mm edge length. When mast is tilted forward, using non-standard fork or loading large goods, the load capacity will be reduced. The load capacity of standard mast at different load center can be known from this load chart.

Configuration number	Configuration
GC2R	Manually operated valve
	Mechanical handle control hydraulic functions
	ZAPI travelling motor controller
	ZAPI lifting motor controller
	ZAPI steering motor controller

WIDE VIEW FULL FREE 3-STAGE MAST

Mast model	Lifting height (mm)		Free lifting height(mm)		Mast height, lowerd(mm)		Load capacity(kg)		Mast tilt angle (front/rear) α / β
	CQD20	CQD25	CQD20	CQD25	CQD20	CQD25	CQD20	CQD25	
ZSM360	3600	3600	980	980	2005	2005	2000	2500	2°/4°
ZSM400	4000	4000	1110	1110	2138	2138	2000	2500	2°/4°
ZSM430	4300	4300	1210	1210	2238	2238	1900	2400	2°/4°
ZSM460	4600	4600	1310	1310	2338	2338	1900	2400	2°/4°
ZSM480	4800	4800	1380	1380	2405	2405	1800	2300	2°/4°
ZSM540	5400	5400	1580	1580	2605	2605	1500	2000	2°/4°
ZSM570	5700	5700	1680	1680	2705	2705	1450	1950	2°/4°
ZSM600	6000	6000	1780	1780	2805	2805	1400	1900	2°/4°
ZSM650	6500	6500	1947	1947	2972	2972	1300	1800	2°/4°

WIDE VIEW MAST

Mast model	Lifting height (mm)		Free lifting height(mm)		Mast height, lowerd(mm)		Load capacity(kg)		Mast tilt angle (front/rear) α / β
	CQD20	CQD25	CQD20	CQD25	CQD20	CQD25	CQD20	CQD25	
M250	2500	2500	80	80	2024	2024	2000	2500	2°/4°
M270	2700	2700	80	80	2124	2124	2000	2500	2°/4°
M300	3000	3000	80	80	2274	2274	2000	2500	2°/4°
M330	3300	3300	80	80	2424	2424	2000	2500	2°/4°
M360	3600	3600	80	80	2574	2574	2000	2500	2°/4°
M400	4000	4000	80	80	2774	2774	2000	2500	2°/4°
M430	4300	4300	80	80	2924	2924	1900	2400	2°/4°
M460	4600	4600	80	80	3074	3074	1900	2400	2°/4°
M500	5000	5000	80	80	3274	3274	1800	2300	2°/4°
M540	5400	5400	80	80	3474	3474	1500	2000	2°/4°

G2 series 2-2.5 t

Three phase AC type motor technology

- Three phase motor AC type motor control on travelling, lifting and steering
- Good acceleration
- Fast and sensitive respond on travel direction shifting
- Free from maintenance motor without carbon brush having long service life and low maintenance cost
- Energy regenerating during deceleration extending operation hours

Newly designed hydraulic system

- Newly designed hydraulic system with high working efficiency
- High power lifting motor
- MOSFET lifting speed governing electric controller
- New type noisy gear pump, high efficiency and long life

Optimized intelligent design

- CAN bus technology
 - Parking brake on slope
 - Operation sequence protection
 - Travelling speed control
 - Lifting speed control
 - Electric controller self protection
 - Dead-man footswitch traction interlock
-

Advanced EPS electric powered steering

- EPS electric powered steering offering easy, flexible, high efficient and mute operation
 - Steering motor controller
 - Automatic centering function
 - Automatic limit on speed and accelerated speed when steering
-

Easy operated thumb switch

- To control travelling functions
 - Clear operating units
-

Six independant braking systems

- Automatic braking when accelerator lever is released
- Emergency brake activated by releasing footswitch
- Parking brake activated by pressing button on the panel
- Automatic hold-on brake
- Parking brake activated by hydraulic control lever
- Emergency isolator



Comfort cab

- The driver's body is fully protected within the truck contours
- Padded waist, head and arm supports
- Easy reach to important operation

Overhead guard

- Overhead guard support for improved operator protection and enhanced visibility to the load
- Fence on top of the overhead guard offering driver wide view
- Beveled view angle design with front ring beam meeting humanized requirements

Displayer

- High quality meter displaying important operating data
- 180° steering angle position display
- Display of battery power and fault code
- Travelling mode selection
- Lifting lock indication
- Hour meter
- Labor hour display

Standard configuration

AC travelling motor
AC lifting motor
AC steering motor
Electrical brake
DC/DC converter
Low noisy gear pump
Control valve (four throw)
3300mm two-stage mast
Integral sideshifter
Standard fork
Backrest
Polyurethane tire
LED meter
Front working light
Vertical battery change
Warning light

Optional device

Three-stage full free lift mast
Two-stage mast
Fork with other length
Fork extension
Monitoring system
Other battery
Battery charger
Alternative colour scheme
Battery on roller for rapid side battery change

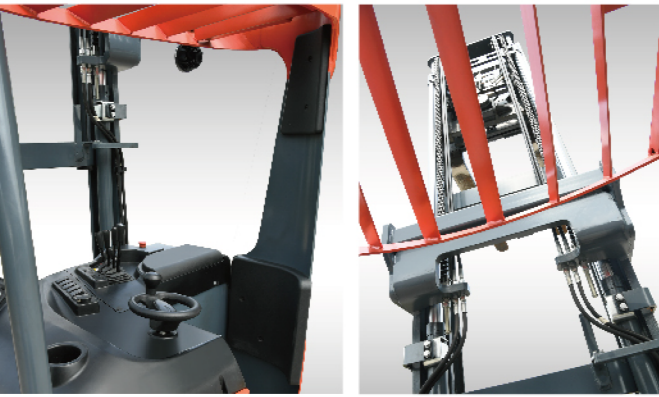

Wide view mast

- Good view when loaded
- Integral sideshifter
- High residual load capacity at high lift height
- Buffering on lifting limit
- Buffering on mast moving forward and backward limit
- Fork tilt
- Lift height range:2500-6500mm



Reliable special designed instrument

Information display

Low voltage indicator

Fault indicator

Hour meter

Enter

Performance selecting button (up)

Performance selecting button (down)

Battery electric quantity indicator

For spare

Handbrake state indicator

Safety switch indicator

Exit

Value setting button (decrease)

Value setting button (increase)



ZAPI standard type meter (for GC2R model)

The reliable special instrument gives a complete display of the vital information, like operation status, fault detection, etc. It ensures the operator predominate the vehicle status more intuitive and convenient.

HELI smart fleet management system (optional)

- Vehicle positioning
- Remote diagnosis
- Remote monitoring
- Maintenance reminder
- Battery management
- Statistical form
- Vehicle management
- Identification recognition (optional)
- Weight management (optional)
- Collision management (optional)

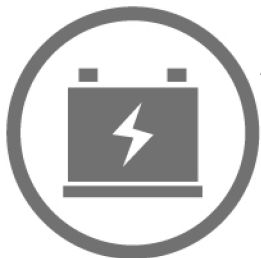

RENEWABLE ENERGY TECHNOLOGIES

With the use of AC controlling renewable energy technologies, the forklift is more energy-saving and the working hour of the battery is extended by 15%



15%

go to heliforklift.ca

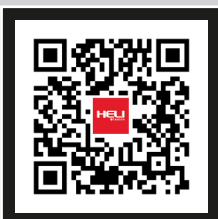

HELI CANADA

5705, place Kubota
 Drummondville, Québec, Canada, J2B 6V4
 1-833-HELICAN
 info@heliforklift.ca
 www.heliforklift.ca