

TL37J

TRAILER MOUNTED BOOM LIFT



- High specification trailer mounted boom lift
- Excellent working envelope including a jib boom
- Hydraulic outriggers for simple set-up
- Proportional controls for easy operation
- Range of power source options

 **snorkel**
www.snorkellifts.com

TRAILER MOUNTED BOOM LIFT

TL37J

DIMENSIONS

	TL37J
Max. working height	12.9m
Max. platform height	10.9m
Max. working outreach	5.6m
Platform width (C)	1.14m
Platform depth (D)	0.7m
Stabiliser footprint (A x B)	3.9m x 3.3m
Towing width (E)	1.61m
Towing length (F)	6.4m
Stowed height (G)	2.1m

PERFORMANCE

Platform capacity (SWL)	215kg
Max. wind speed	12.5m/s
Jib length	1.3m
Jib arc	130°
Platform rotation	160°
Superstructure rotation (non-continuous)	640°
Tires	165/80 R13
Controls	hydraulic proportional

POWER

Power source	24V DC battery (4 x 6V 225Ah batteries)
Power options	gasoline, bi-energy (combustion & battery), AC electric

WEIGHT

Weight (DC)	1,568kg
-------------	---------

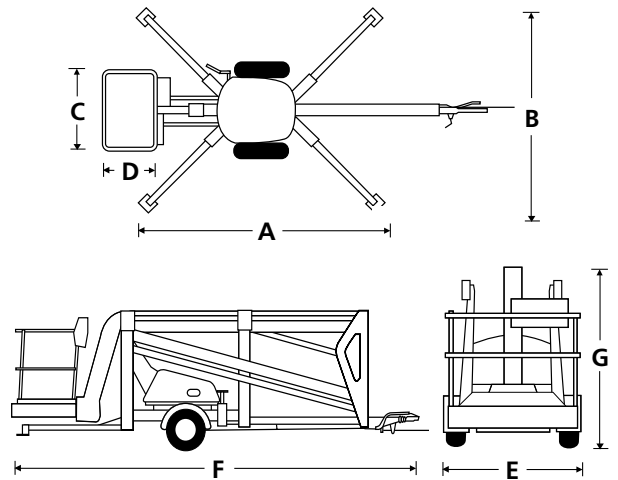

STANDARD FEATURES

- 1.3m jib with 130° working arc
- In-line boom design for maximum rigidity
- Hydraulic outriggers
- Hand pump emergency lowering from platform
- Lock valves on all hydraulic cylinders
- Power line to platform
- Proportional live hydraulic controls
- 2 year parts & labor, 5 year structural warranty
- ANSI compliant

OPTIONS

- Special paint colors
- Friction drive assist package
- Flashing amber light
- Work lights in platform
- Nylon spreader pads (set of 4)
- Environmental hydraulic oil
- CSA compliant

WORKING ENVELOPE

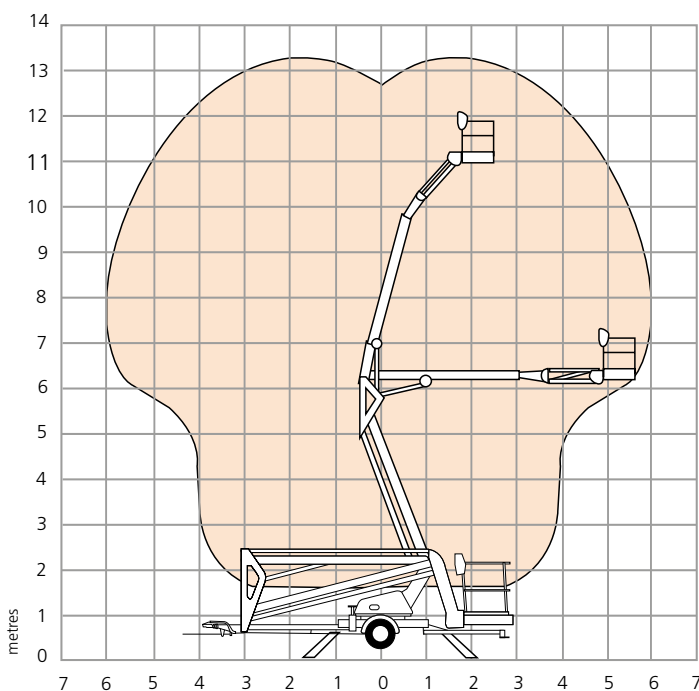

snorkel www.snorkellifts.com

P.O. Box 1160
 St. Joseph, MO 64502-1160, USA
 Tel: 1 (785) 989-3000
 Toll-free: 1 (800) 255-0317
 Fax: 1 (785) 989-3070
 Email: sales.usa@snorkellifts.com